

HIMatrix

Safety-Related Controller

F2 DO 4 01 Manual



HIMA Paul Hildebrandt GmbH + Co KG
Industrial Automation

All HIMA products mentioned in this manual are protected by the HIMA trade-mark. Unless noted otherwise, this also applies to other manufacturers and their respective products referred to herein.

HIMax[®], HIMatrix[®], SILworX[®], XMR[®] and FlexSILon[®] are registered trademarks of HIMA Paul Hildebrandt GmbH + Co KG.

All of the instructions and technical specifications in this manual have been written with great care and effective quality assurance measures have been implemented to ensure their validity. For questions, please contact HIMA directly. HIMA appreciates any suggestion on which information should be included in the manual.

Equipment subject to change without notice. HIMA also reserves the right to modify the written material without prior notice.

For further information, refer to the HIMA DVD and our website at <http://www.hima.de> and <http://www.hima.com>.

© Copyright 2013, HIMA Paul Hildebrandt GmbH + Co KG

All rights reserved

Contact

HIMA contact details:

HIMA Paul Hildebrandt GmbH + Co KG

P.O. Box 1261

68777 Brühl, Germany

Phone: +49 6202 709-0

Fax: +49 6202 709-107

E-mail: info@hima.com

Revision index	Revisions	Type of change	
		technical	editorial
1.00	Added: Configuration with SILworX	X	X
1.01	Deleted: Chapter <i>Monitoring the Temperature State</i> integrated in the system manual		X
2.00	Revised: Chapters 3.4.1 and 3.4.2.1 Added: SIL 4 certified according to EN 50126, EN 50128 and EN 50129, Chapter 4.1.2	X	X

Table of Contents

1	Introduction	5
1.1	Structure and Use of this Manual	5
1.2	Target Audience	6
1.3	Formatting Conventions	7
1.3.1	Safety Notes	7
1.3.2	Operating Tips	8
2	Safety	9
2.1	Intended Use	9
2.1.1	Environmental Requirements	9
2.1.2	ESD Protective Measures	9
2.2	Residual Risk	10
2.3	Safety Precautions	10
2.4	Emergency Information	10
3	Product Description	11
3.1	Safety Function	11
3.1.1	Safety-Related Digital Outputs	11
3.1.1.1	Reaction in the Event of a Fault	12
3.2	Equipment, Scope of Delivery	13
3.2.1	IP Address and System ID (SRS)	13
3.3	Type Label	14
3.4	Structure	15
3.4.1	LED Indicators	16
3.4.1.1	Operating Voltage LED	16
3.4.1.2	System LEDs	16
3.4.1.3	Communication LEDs	17
3.4.1.4	I/O LEDs	17
3.4.2	Communication	18
3.4.2.1	Connections for Ethernet Communication	18
3.4.2.2	Network Ports Used for Ethernet Communication	18
3.4.3	Reset Key	19
3.5	Product Data	20
3.6	Certified HIMatrix F2 DO 4 01	21
4	Start-up	22
4.1	Installation/Mounting	22
4.1.1	Connecting the Digital Outputs	22
4.1.2	Cable Plugs	23
4.1.3	Mounting the F2 DO 4 01 in Zone 2	24
4.2	Configuration	25

4.3	Configuration with SILworX	25
4.3.1	Parameters and Error Codes for the Output	25
4.3.2	Digital Outputs for F2 DO 4 01	25
4.3.2.1	Tab: Module	26
4.3.2.2	Tab: DO 4: Channels	27
4.4	Configuration with ELOP II Factory	27
4.4.1	Configuring the Outputs	27
4.4.2	Signals and Error Codes for the Output	27
4.4.3	Digital Outputs for F2 DO 4 01	28
5	Operation	29
5.1	Handling	29
5.2	Diagnosis	29
6	Maintenance	30
6.1	Faults	30
6.2	Maintenance Measures	30
6.2.1	Loading the Operating System	30
6.2.2	Proof Test	30
7	Decommissioning	31
8	Transport	32
9	Disposal	33
	Appendix	35
	Glossary	35
	Index of Figures	36
	Index of Tables	37
	Index	38

1 Introduction

This manual describes the technical characteristics of the device and its use. It provides information on how to install, start up and configure the module.

1.1 Structure and Use of this Manual

The content of this manual is part of the hardware description of the HIMatrix programmable electronic system.

This manual is organized in the following main chapters:

- Introduction
- Safety
- Product Description
- Start-up
- Operation
- Maintenance
- Decommissioning
- Transport
- Disposal

HIMatrix remote I/Os are available for the programming tools SILworX and ELOP II Factory. Which programming tool can be used, depends on the processor operating system of the HIMatrix remote I/O, refer to the following table:

Programming tool	Processor operating system
SILworX	CPU OS V7 and higher
ELOP II Factory	CPU OS up to V6.x

Table 1: Programming Tools for HIMatrix Remote I/Os

In the manual, the differences are specified by using:

- Separated chapters
- Tables differentiating among the versions

i **Projects created with ELOP II Factory cannot be edited with SILworX, and vice versa!**

i Compact controllers and remote I/Os are referred to as *devices*.

Additionally, the following documents must be taken into account:

Name	Content	Document number
HIMatrix System Manual Compact Systems	Hardware description of the HIMatrix compact systems	HI 800 141 E
HIMatrix System Manual Modular System F60	Hardware description of the HIMatrix modular system	HI 800 191 E
HIMatrix Safety Manual	Safety functions of the HIMatrix system	HI 800 023 E
HIMatrix Safety Manual for Railway Applications	Safety functions of the HIMatrix system using the HIMatrix in railway applications	HI 800 437 E
SILworX Online Help	Instructions on how to use SILworX	-
ELOP II Factory Online Help	Instructions on how to use ELOP II Factory, Ethernet IP protocol	-
SILworX First Steps	Introduction to SILworX using the HIMax system as an example	HI 801 103 E
ELOP II Factory First Steps	Introduction to ELOP II Factory	HI 800 006 E

Table 2: Additional Relevant Documents

The latest manuals can be downloaded from the HIMA website at www.hima.com. The revision index on the footer can be used to compare the current version of existing manuals with the Internet edition.

1.2 Target Audience

This document addresses system planners, configuration engineers, programmers of automation devices and personnel authorized to implement, operate and maintain the modules and systems. Specialized knowledge of safety-related automation systems is required.

1.3 Formatting Conventions

To ensure improved readability and comprehensibility, the following fonts are used in this document:

Bold	To highlight important parts. Names of buttons, menu functions and tabs that can be clicked and used in the programming tool.
<i>Italics</i>	For parameters and system variables
Courier	Literal user inputs
RUN	Operating state are designated by capitals
Chapter 1.2.3	Cross references are hyperlinks even though they are not particularly marked. When the cursor hovers over a hyperlink, it changes its shape. Click the hyperlink to jump to the corresponding position.

Safety notes and operating tips are particularly marked.

1.3.1 Safety Notes

The safety notes are represented as described below.

These notes must absolutely be observed to reduce the risk to a minimum. The content is structured as follows:

- Signal word: warning, caution, notice
- Type and source of risk
- Consequences arising from non-observance
- Risk prevention

SIGNAL WORD



Type and source of risk!
Consequences arising from non-observance
Risk prevention

The signal words have the following meanings:

- Warning indicates hazardous situation which, if not avoided, could result in death or serious injury.
- Caution indicates hazardous situation which, if not avoided, could result in minor or modest injury.
- Notice indicates a hazardous situation which, if not avoided, could result in property damage.

NOTE



Type and source of damage!
Damage prevention

1.3.2 Operating Tips

Additional information is structured as presented in the following example:

i The text corresponding to the additional information is located here.

Useful tips and tricks appear as follows:

TIP The tip text is located here.

2 Safety

All safety information, notes and instructions specified in this document must be strictly observed. The product may only be used if all guidelines and safety instructions are adhered to.

This product is operated with SELV or PELV. No imminent risk results from the product itself. The use in Ex-zone is permitted if additional measures are taken.

2.1 Intended Use

HIMatrix components are designed for assembling safety-related controller systems.

When using the components in the HIMatrix system, comply with the following general requirements.

2.1.1 Environmental Requirements

Requirement type	Range of values ¹⁾
Protection class	Protection class III in accordance with IEC/EN 61131-2
Ambient temperature	0...+60 °C
Storage temperature	-40...+85 °C
Pollution	Pollution degree II in accordance with IEC/EN 61131-2
Altitude	< 2000 m
Housing	Standard: IP20
Supply voltage	24 VDC
¹⁾ The values specified in the technical data apply and are decisive for devices with extended environmental requirements.	

Table 3: Environmental Requirements

Exposing the HIMatrix system to environmental conditions other than those specified in this manual can cause the HIMatrix system to malfunction.

2.1.2 ESD Protective Measures

Only personnel with knowledge of ESD protective measures may modify or extend the system or replace devices.

NOTE



Device damage due to electrostatic discharge!

- When performing the work, make sure that the workspace is free of static, and wear an ESD wrist strap.
- If not used, ensure that the device is protected from electrostatic discharge, e.g., by storing it in its packaging.

2.2 Residual Risk

No imminent risk results from a HIMatrix system itself.

Residual risk may result from:

- Faults related to engineering
- Faults related to the user program
- Faults related to the wiring

2.3 Safety Precautions

Observe all local safety requirements and use the protective equipment required on site.

2.4 Emergency Information

A HIMatrix system is a part of the safety equipment of a site. If a device or a module fails, the system enters the safe state.

In case of emergency, no action that may prevent the HIMatrix systems from operating safely is permitted.

3 Product Description

The safety-related **F2 DO 4 01** remote I/O is a compact system in a metal housing with 4 digital outputs.

The remote I/O is available in various model variants for SILworX and ELOP II Factory, see Table 4.

Remote I/Os are connected to individual HIMax or HIMatrix controllers via **safeethernet**. They are used to extend the I/O level, but are not able to run any user program by themselves.

The remote I/O is suitable for mounting in Ex-zone 2, see Chapter 4.1.3.

The device is TÜV-certified for safety-related applications up to SIL 3 (IEC 61508, IEC 61511 and IEC 62061), Cat. 4 and PL e (EN ISO 13849-1) and SIL 4 (EN 50126, EN 50128 and EN 50129).

Further safety standards, application standards and test standards are specified in the certificates available on the HIMA website.

3.1 Safety Function

The remote I/O is equipped with safety-related outputs. These outputs are safely assigned their values by the connected controller via **safeethernet**.

3.1.1 Safety-Related Digital Outputs

The remote I/O is equipped with 4 digital outputs. The state (HIGH, LOW) of each output is signaled by an individual LED (HIGH, LOW).

Up to the maximum ambient temperature (60 °C), each of the 4 outputs can be loaded with a maximum of 5 A.

The external wire of an output is not monitored, however, a detected short-circuit is signaled.

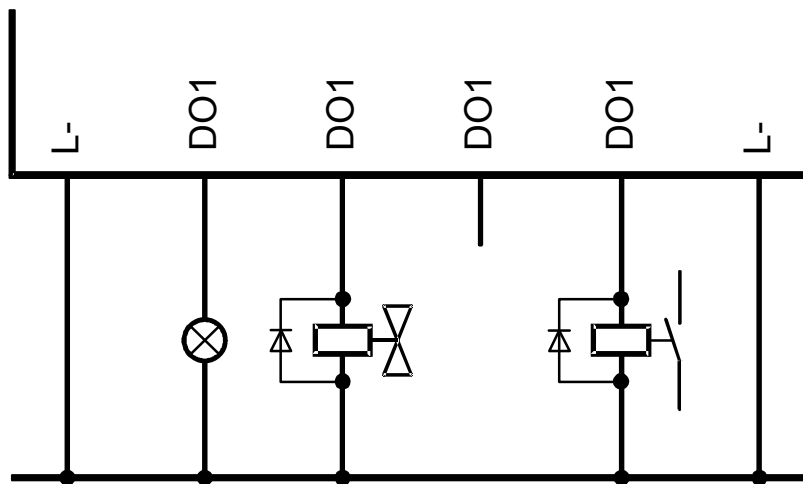

Figure 1: Connection of Actuators to Outputs

The redundant connection of two outputs must be decoupled with diodes.

⚠ WARNING

For connecting a load to a 1-pole switching output, use the corresponding L- ground of the respective channel group (2-pole connection) to ensure that the internal protective circuit can function.

Inductive loads may be connected with no free-wheeling diode on the actuator. However, HIMA strongly recommends connecting a protective diode directly to the actuator.

If an overload occurs, one or all digital outputs are switched off. If the overload is removed, the outputs are switched on again automatically, see Table 12.

3.1.1.1 Reaction in the Event of a Fault

If the device detects a faulty signal on a digital output, the affected module output is set to the safe (de-energized) state using the safety switches.

If a device fault occurs, all digital outputs are switched off.

In both cases, the device activates the *FAULT* LED.

The error code allows the user to configure additional fault reactions in the user program.

3.2 Equipment, Scope of Delivery

The following table specifies the available remote I/O variants:

Designation	Description
F2 DO 4 01	Remote I/O (4 digital outputs), Operating temperature: 0...+60 °C, for ELOP II Factory programming tool
F2 DO 4 01 SILworX	Remote I/O (4 digital outputs), Operating temperature: 0...+60 °C, for SILworX programming tool

Table 4: Available Variants

3.2.1 IP Address and System ID (SRS)

A transparent label is delivered with the device to allow one to note the IP address and the system ID (SRS for system rack slot) after a change.

IP ____ . ____ . ____ . ____ SRS ____ . ____ . ____

Default value for IP address: 192.168.0.99

Default value for SRS: 60 000.200.0 (SILworX)

60 000.0.0 (ELOP II Factory)

The label must be affixed such that the ventilation slots in the housing are not obstructed.

Refer to the First Steps manual of the programming tool for more information on how to modify the IP address and the system ID.

3.3 Type Label

The type plate contains the following details:

- Product name
- Bar code (1D or 2D code)
- Part no.
- Production year
- Hardware revision index (HW Rev.)
- Firmware revision index (FW Rev.)
- Operating voltage
- Mark of conformity

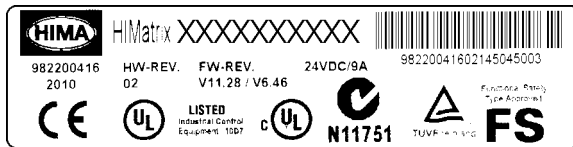

Figure 2: Sample Type Label

3.4 Structure

This chapter describes the layout and function of the remote I/Os, and their communication via safeethernet.

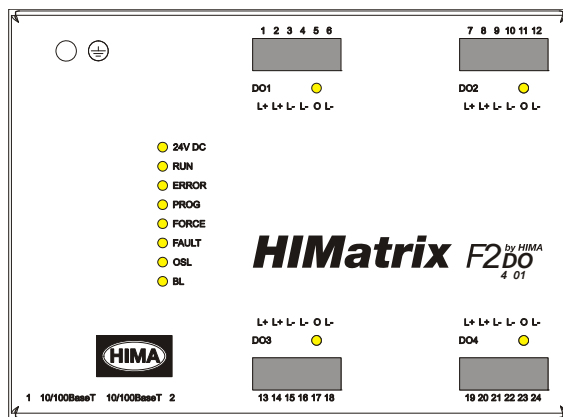

Figure 3: Front View

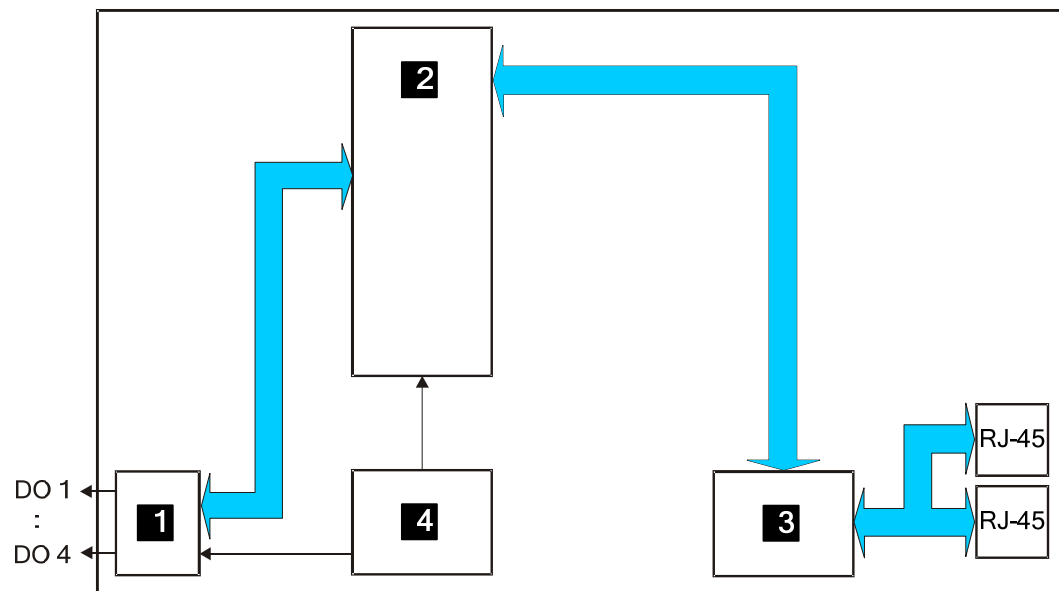

Figure 4: Block Diagram

3.4.1 LED Indicators

The light-emitting diodes (LEDs) indicate the operating state of the remote I/O. The LEDs are classified as follows:

- Operating voltage LED
- System LEDs
- Communication LEDs
- I/O LEDs

3.4.1.1 Operating Voltage LED

LED	Color	Status	Description
24 VDC	Green	On	24 VDC operating voltage present
		Off	No operating voltage

Table 5: Operating Voltage LED

3.4.1.2 System LEDs

While the system is being booted, all LEDs are lit simultaneously.

LED	Color	Status	Description
RUN	Green	On	Device in RUN, normal operation
		Blinking	Device in STOP A new operating system is being loaded.
		Off	The device is not in the RUN state.
ERROR	Red	On	The device is in the ERROR STOP state. Internal fault detected by self-tests, e.g., hardware faults or cycle time overrun. The processor system can only be restarted with a command from the PADT (reboot).
		Blinking	If ERROR blinks and all others LEDs are lit simultaneously, the boot loader has detected an operating system fault in the flash memory and waits for a new operating system to be loaded.
		Off	No faults detected.
PROG	Yellow	On	A new configuration is being loaded into the device.
		Blinking	The device switches from INIT to STOP A new operating system is being loaded into the flash ROM.
		Off	No configuration or operating system is being loaded.
FORCE	Yellow	Off	The FORCE LED of a remote I/O is not functioning. The FORCE LED of the associated controller serves to signal the forcing of a remote I/O.
FAULT	Yellow	On	The loaded configuration is not valid. The new operating system is corrupted (after OS download).
		Blinking	Fault while loading a new operating system One or multiple I/O faults occurred.
		Off	None of the described faults occurred.
OSL	Yellow	Blinking	Operating system emergency loader active.
		Off	Operating system emergency loader inactive.
BL	Yellow	Blinking	OS and OSL binary defective or hardware fault, INIT_FAIL.
		Off	None of the described faults occurred.

Table 6: System LEDs

3.4.1.3 Communication LEDs

All RJ-45 connectors are provided with a small green and a yellow LEDs. The LEDs signal the following states:

LED	Status	Description
Green	On	Full duplex operation
	Blinking	Collision
	Off	Half duplex operation, no collision
Yellow	On	Connection available
	Blinking	Interface activity
	Off	No connection available

Table 7: Ethernet Indicators

3.4.1.4 I/O LEDs

LED	Color	Status	Description
DO 1...4	Yellow	On	The related channel is active (energized).
		Off	The related channel is inactive (de-energized).

Table 8: I/O LEDs

3.4.2 Communication

The remote I/O communicates with the associated controller via **safeethernet**.

3.4.2.1 Connections for Ethernet Communication

Property	Description
Ports	2 x RJ-45
Transfer standard	10BASE-T/100BASE-Tx, half and full duplex
Auto negotiation	Yes
Auto crossover	Yes
IP address	Freely configurable ¹⁾
Subnet mask	Freely configurable ¹⁾
Supported protocols	<ul style="list-style-type: none"> ▪ Safety-related: safeethernet ▪ Standard protocols: Programming and debugging tool (PADT), SNTP
¹⁾ The general rules for assigning IP address and subnet masks must be adhered to.	

Table 9: Ethernet interfaces Properties

The two RJ-45 connectors with integrated LEDs are located on the bottom left-hand side of the housing. For more information on the communication LEDs, refer to Chapter 3.4.1.3.

The connection parameters are read based on the MAC address (media access control address) defined during manufacturing.

The MAC address for the remote I/O is specified on a label located above the two RJ-45 connectors (1 and 2).

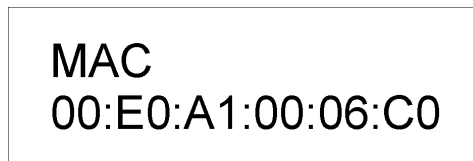

Figure 5: Sample MAC Address Label

The remote I/O is equipped with an integrated switch for Ethernet communication. For further information on the integrated switch and **safeethernet**, refer to Chapter *Communication* of the system manual for compact systems (HI 800 141 E).

3.4.2.2 Network Ports Used for Ethernet Communication

UDP ports	Use
8000	Programming and operation with the programming tools
8001	Configuration of the remote I/O using the PES (ELOP II Factory)
8004	Configuration of the remote I/O using the PES (SILworX)
6010	safeethernet
123	SNTP (time synchronization between PES and remote I/O, PES and external devices)

Table 10: Network Ports in Use

3.4.3 Reset Key

The remote I/O is equipped with a reset key. The key is only required if the user name or password for administrator access is not known. If only the IP address set for the remote I/O does not match the PADT (PC), the connection can be established with a `Route add` entry on the PC.

The key can be accessed through a small round hole located approximately 5 cm from the upper left-hand side of the housing. The key is engaged using a suitable pin made of insulating material to avoid short-circuits within the remote I/O.

The reset is only effective if the remote I/O is rebooted (switched off and on) while the key is simultaneously engaged for at least 20 s. Engaging the key during operation has no effect.

Properties and behavior of the remote I/O after a reboot with engaged reset key:

- Connection parameters (IP address and system ID) are set to the default values.
- All accounts are deactivated except for the default account administrator with empty password.

After a new reboot without the reset key engaged, the connection parameters (IP address and system ID) and accounts become effective.

- Those configured by the user.
- Those valid prior to rebooting with the reset key engaged, if no changes were performed.

3.5 Product Data

General	
Response time	≥ 20 ms
Ethernet interfaces	2 x RJ-45, 10BASE-T/100BASE-Tx with integrated switch
Operating voltage	24 VDC, -15...+20 %, $r_{PP} \leq 15 \%$, from a power supply unit with safe insulation in accordance with IEC 61131-2
Fuse (external)	10 A time-lag (T)
Operating temperature	0...+60 °C
Storage temperature	-40...+85 °C
Type of protection	IP20
Max. dimensions (without plug)	Width: 152 mm (with housing screws) Height: 114 mm (with fixing bolt) Depth: 66 mm (with earthing screw)
Weight	0.8 kg

Table 11: Product Data

Digital outputs	
Number of outputs	4 (non-galvanically separated)
Total current permitted for all outputs channels	max. 20 A
Output voltage	≥ L+ minus 1 V
Output current	max. 5 A
Lamp load	max. 60 W
Inductive load	max. 500 mH
Internal voltage drop	max. 1 V at 5 A
Leakage current (with low level)	max. 1 mA at 1 V
Behavior upon overload	The affected output is switched off and cyclically switched on again

Table 12: Specifications for the Digital Outputs

3.6 Certified HIMatrix F2 DO 4 01

HIMatrix F2 DO 4 01	
CE	EMC, ATEX Zone 2
TÜV	IEC 61508 1-7:2000 up to SIL 3 IEC 61511:2004 EN ISO 13849-1:2008 up to Cat. 4 und PL e
UL Underwriters Laboratories Inc.	ANSI/UL 508, NFPA 70 – Industrial Control Equipment CSA C22.2 No.142 UL 1998 Software Programmable Components NFPA 79 Electrical Standard for Industrial Machinery IEC 61508
FM Approvals	Class I, DIV 2, Groups A, B, C and D Class 3600, 1998 Class 3611, 1999 Class 3810, 1989 Including Supplement #1, 1995 CSA C22.2 No. 142 CSA C22.2 No. 213
TÜV CENELEC	Railway applications EN 50126: 1999 up to SIL 4 EN 50128: 2001 up to SIL 4 EN 50129: 2003 up to SIL 4

Table 13: Certified HIMatrix F2 DO 4 01

4 Start-up

To start up the remote I/O, it must be mounted, connected and configured in the programming tool.

4.1 Installation/Mounting

The remote I/O is mounted on a 35 mm DIN rail such as described in the HIMatrix system manual for compact systems.

When laying cables (long cables, in particular), take appropriate measures to avoid interference, e.g., by separating the signal lines from the power lines.

When dimensioning the cables, ensure that their electrical properties have no negative impact on the measuring circuit.

4.1.1 Connecting the Digital Outputs

Use the following terminals to connect the digital outputs:

Terminal	Designation	Function (output DO1)
1, 2	L+	Supply line for output 1
3, 4	L-	Ground
5	O	Digital output 1
6	L-	Ground
Terminal	Designation	Function (output DO2)
7, 8	L+	Supply line for output 2
9, 10	L-	Ground
11	O	Digital output 2
12	L-	Ground
Terminal	Designation	Function (output DO3)
13, 14	L+	Supply line for output 3
15, 16	L-	Ground
17	O	Digital output 3
18	L-	Ground
Terminal	Designation	Function (output DO4)
19, 20	L+	Supply line for output 4
21, 22	L-	Ground
23	O	Digital output 4
24	L-	Ground

Table 14: Terminal Assignment for the Digital Outputs

4.1.2 Cable Plugs

Cable plugs attached to the pin headers of the devices are used to connect to the power supply and to the field zone. The cable plugs are included within the scope of delivery of the HIMatrix devices and modules.

The devices power supply connections feature the following properties:

Connection to the power supply	
Cable plugs	Four poles, screw terminals
Wire cross-section	0.2...2.5 mm ² (single-wire) 0.2...2.5 mm ² (finely stranded) 0.2...2.5 mm ² (with wire end ferrule)
Stripping length	10 mm
Screwdriver	Slotted 0.6 x 3.5 mm
Tightening torque	0.4...0.5 Nm

Table 15: Power Supply Cable Plug Properties

Connection to the field zone	
Number of cable plugs	4 pieces, six poles, screw terminals
Wire cross-section	0.2...1.5 mm ² (single-wire) 0.2...1.5 mm ² (finely stranded) 0.2...1.5 mm ² (with wire end ferrule)
Stripping length	6 mm
Screwdriver	Slotted 0.4 x 2.5 mm
Tightening torque	0.2...0.25 Nm

Table 16: Input and Output Cable Plug Properties

4.1.3 Mounting the F2 DO 4 01 in Zone 2
(EC Directive 94/9/EC, ATEX)

The remote I/O is suitable for mounting in zone 2. Refer to the corresponding declaration of conformity available on the HIMA website.

When mounting the device, observe the special conditions specified in the following section.

Specific Conditions X

1. Mount the remote I/O in an enclosure that meets the EN 60079-15 requirements and achieves a type of protection of at least IP54, in accordance with EN 60529. Provide the device with the following label:

Work is only permitted in the de-energized state

Exception:

If a potentially explosive atmosphere has been precluded, work can be also performed when the device is under voltage.

2. The enclosure in use must be able to safely dissipate the generated heat. Depending on the output load and supply voltage, the HIMatrix F2 DO 4 01 module has a power dissipation ranging between 12 W and 55 W.
3. Protect the HIMatrix F2 DO 4 01 with a 10 A time-lag fuse.
The 24 VDC power must come from a power supply unit with safe isolation. Use power supply units of type PELV or SELV only.
4. Applicable standards:

VDE 0170/0171 Part 16,	DIN EN 60079-15: 2004-5
VDE 0165 Part 1,	DIN EN 60079-14: 1998-08

Pay particular attention to the following sections

DIN EN 60079-15:

Chapter 5	Design
Chapter 6	Terminals and cabling
Chapter 7	Air and creeping distances
Chapter 14	Connectors

DIN EN 60079-14:

Chapter 5.2.3	Equipment for use in zone 2
Chapter 9.3	Cabling for zones 1 and 2
Chapter 12.2	Equipment for zones 1 and 2

The remote I/O is additionally equipped with the label represented below:

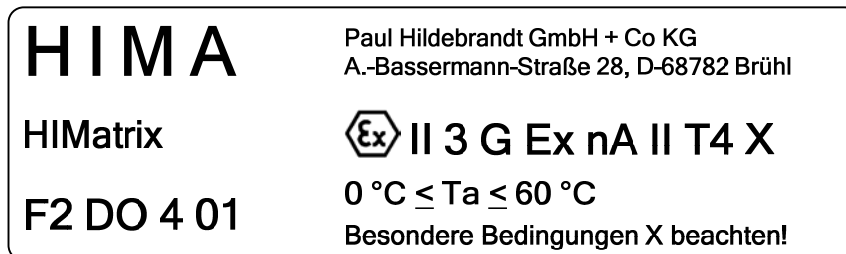

Figure 6: Label for Ex Conditions

4.2 Configuration

The remote I/O can be configured using a programming tool, SILworX or ELOP II Factory. Which programming tool should be used, depends on the revision status of the operating system (firmware):

- SILworX is required for CPU OS V7 and higher.
- ELOP II Factory is required for CPU OS up to V6.x.

i

How to switch between operating systems is described in Chapter *Loading Operating Systems* of the system manual for compact systems (HI 800 141 E).

4.3 Configuration with SILworX

In the Hardware Editor, the remote I/Os are represented like a base plate equipped with the following modules:

- Processor module (CPU)
- Output module (DO 4)

Double-click the module to open the Detail View with the corresponding tabs. The tabs are used to assign the global variables configured in the user program to the system parameter of the corresponding module.

The following tables present the statuses and parameters for the remote I/O in the same order given in the Hardware Editor.

4.3.1 Parameters and Error Codes for the Output

The following tables specify the system parameters that can be read and set for the outputs, including the corresponding error codes.

In the user program, the error codes can be read using the variables assigned within the logic.

The error codes can also be displayed in SILworX.

4.3.2 Digital Outputs for F2 DO 4 01

The following tables present the statuses and parameters for the output module (DO 4) in the same order as given in the Hardware Editor.

4.3.2.1 Tab **Module**

The **Module** tab contains the following system parameters:

System parameter	Data type	R/W	Description	
DO.Error Code	WORD	R	Error codes for all digital outputs	
			Coding	Description
			0x0001	Fault within the digital outputs
			0x0002	Test of safety shutdown returns a fault
			0x0004	Test of auxiliary voltage returns a fault
			0x0008	FTT test of test pattern faulty
			0x0010	Output switch test pattern faulty
			0x0020	Output switch test pattern (shutdown test of the outputs) faulty
			0x0040	Active shutdown via WD faulty
			0x0400	FTT test: 1st temperature threshold exceeded
0x0800	FTT test: 2nd temperature threshold exceeded			
Module Error Code	WORD	R	Module error code	
			Coding	Description
			0x0000	I/O processing, if required with errors, see other error codes
			0x0001	No I/O processing (remote I/O not in RUN)
			0x0002	No I/O processing during the booting test
			0x0004	Manufacturer interface operating
			0x0010	No I/O processing: invalid configuration
			0x0020	No I/O processing: fault rate exceeded
0x0040/ 0x0080	No I/O processing: configured module not plugged in			
Module SRS	UDINT	R	Slot number (System Rack Slot)	
Module Type	UINT	R	Type of module, target value: 0x004B [75 _{dec}]	

Table 17: SILworX - System Parameters for Digital Outputs, **Module** Tab

4.3.2.2 Tab **DO 4: Channels**

The **DO 4: Channels** tab contains the following system parameters.

System parameter	Data type	R/W	Description														
Channel no.	---	R	Channel number, defined by default														
-> Error Code [BYTE]	BYTE	R	Error codes for the digital output channels <table border="1" style="margin-left: 20px;"> <thead> <tr> <th>Coding</th> <th>Description</th> </tr> </thead> <tbody> <tr> <td>0x01</td> <td>Fault in the digital output module</td> </tr> <tr> <td>0x02</td> <td>Channel shutdown due to overload</td> </tr> <tr> <td>0x04</td> <td>Error while reading back the digital outputs</td> </tr> <tr> <td>0x08</td> <td>Error while reading back the status of the digital outputs</td> </tr> <tr> <td>0x10</td> <td>FTT test: Temperature threshold exceeded</td> </tr> <tr> <td>0x20</td> <td>FTT test: Monitoring of auxiliary voltage is faulty</td> </tr> </tbody> </table>	Coding	Description	0x01	Fault in the digital output module	0x02	Channel shutdown due to overload	0x04	Error while reading back the digital outputs	0x08	Error while reading back the status of the digital outputs	0x10	FTT test: Temperature threshold exceeded	0x20	FTT test: Monitoring of auxiliary voltage is faulty
Coding	Description																
0x01	Fault in the digital output module																
0x02	Channel shutdown due to overload																
0x04	Error while reading back the digital outputs																
0x08	Error while reading back the status of the digital outputs																
0x10	FTT test: Temperature threshold exceeded																
0x20	FTT test: Monitoring of auxiliary voltage is faulty																
Value [BOOL] ->	BOOL	W	Output value for DO channels: 1 = output energized 0 = output de-energized														

Table 18: SILworX - System Parameters for Digital Outputs, **DO 4: Channels** Tab

4.4 Configuration with ELOP II Factory

4.4.1 Configuring the Outputs

The signals previously defined in the Signal Editor (Hardware Management) are assigned to the individual channels (outputs) using ELOP II Factory. Refer to the system manual for compact systems for more details

The following chapter describes the system signals used for assigning signals in the controller.

4.4.2 Signals and Error Codes for the Output

The following tables specify the system signals that can be read and set for the outputs, including the corresponding error codes.

In the user program, the error codes can be read using the signals assigned within the logic.

The error codes can also be displayed in ELOP II Factory.

4.4.3 Digital Outputs for F2 DO 4 01

System signal	R/W	Description																				
Mod.SRS [UDINT]	R	Slot number (System Rack Slot)																				
Mod. Type [UINT]	R	Type of module, target value: 0x004B [75 _{dec}]																				
Mod. Error Code [WORD]	R	Module error code																				
		<table border="1"> <thead> <tr> <th>Coding</th> <th>Description</th> </tr> </thead> <tbody> <tr> <td>0x0000</td> <td>I/O processing, if required with errors see other error codes</td> </tr> <tr> <td>0x0001</td> <td>No I/O processing (remote I/O not in RUN)</td> </tr> <tr> <td>0x0002</td> <td>No I/O processing during the booting test</td> </tr> <tr> <td>0x0004</td> <td>Manufacturer interface operating</td> </tr> <tr> <td>0x0010</td> <td>No I/O processing: invalid configuration</td> </tr> <tr> <td>0x0020</td> <td>No I/O processing: fault rate exceeded</td> </tr> <tr> <td>0x0040/ 0x0080</td> <td>No I/O processing: configured module not plugged in</td> </tr> </tbody> </table>	Coding	Description	0x0000	I/O processing, if required with errors see other error codes	0x0001	No I/O processing (remote I/O not in RUN)	0x0002	No I/O processing during the booting test	0x0004	Manufacturer interface operating	0x0010	No I/O processing: invalid configuration	0x0020	No I/O processing: fault rate exceeded	0x0040/ 0x0080	No I/O processing: configured module not plugged in				
		Coding	Description																			
		0x0000	I/O processing, if required with errors see other error codes																			
		0x0001	No I/O processing (remote I/O not in RUN)																			
		0x0002	No I/O processing during the booting test																			
		0x0004	Manufacturer interface operating																			
		0x0010	No I/O processing: invalid configuration																			
		0x0020	No I/O processing: fault rate exceeded																			
0x0040/ 0x0080	No I/O processing: configured module not plugged in																					
DOy.Error Code [WORD]	R	Error codes for all digital outputs																				
		<table border="1"> <thead> <tr> <th>Coding</th> <th>Description</th> </tr> </thead> <tbody> <tr> <td>0x0001</td> <td>Fault within the digital outputs</td> </tr> <tr> <td>0x0002</td> <td>Test of safety shutdown returns a fault</td> </tr> <tr> <td>0x0004</td> <td>Test of auxiliary voltage returns a fault</td> </tr> <tr> <td>0x0008</td> <td>FTT test of test pattern faulty</td> </tr> <tr> <td>0x0010</td> <td>Output switch test pattern faulty</td> </tr> <tr> <td>0x0020</td> <td>Output switch test pattern (shutdown test of the outputs) faulty</td> </tr> <tr> <td>0x0040</td> <td>Active shutdown via WD faulty</td> </tr> <tr> <td>0x0400</td> <td>FTT test: 1st temperature threshold exceeded</td> </tr> <tr> <td>0x0800</td> <td>FTT test: 2nd temperature threshold exceeded</td> </tr> </tbody> </table>	Coding	Description	0x0001	Fault within the digital outputs	0x0002	Test of safety shutdown returns a fault	0x0004	Test of auxiliary voltage returns a fault	0x0008	FTT test of test pattern faulty	0x0010	Output switch test pattern faulty	0x0020	Output switch test pattern (shutdown test of the outputs) faulty	0x0040	Active shutdown via WD faulty	0x0400	FTT test: 1st temperature threshold exceeded	0x0800	FTT test: 2nd temperature threshold exceeded
		Coding	Description																			
		0x0001	Fault within the digital outputs																			
		0x0002	Test of safety shutdown returns a fault																			
		0x0004	Test of auxiliary voltage returns a fault																			
		0x0008	FTT test of test pattern faulty																			
		0x0010	Output switch test pattern faulty																			
		0x0020	Output switch test pattern (shutdown test of the outputs) faulty																			
0x0040	Active shutdown via WD faulty																					
0x0400	FTT test: 1st temperature threshold exceeded																					
0x0800	FTT test: 2nd temperature threshold exceeded																					
DOy[xx].Error Code [BYTE]	R	Error codes for the digital output channels																				
		<table border="1"> <thead> <tr> <th>Coding</th> <th>Description</th> </tr> </thead> <tbody> <tr> <td>0x01</td> <td>Fault in the digital output module</td> </tr> <tr> <td>0x02</td> <td>Channel shutdown due to overload</td> </tr> <tr> <td>0x04</td> <td>Error while reading back the digital outputs</td> </tr> <tr> <td>0x08</td> <td>Error while reading back the status of the digital outputs</td> </tr> <tr> <td>0x10</td> <td>FTT test: Temperature threshold exceeded</td> </tr> <tr> <td>0x20</td> <td>FTT test: Monitoring of auxiliary voltage is faulty</td> </tr> </tbody> </table>	Coding	Description	0x01	Fault in the digital output module	0x02	Channel shutdown due to overload	0x04	Error while reading back the digital outputs	0x08	Error while reading back the status of the digital outputs	0x10	FTT test: Temperature threshold exceeded	0x20	FTT test: Monitoring of auxiliary voltage is faulty						
		Coding	Description																			
		0x01	Fault in the digital output module																			
		0x02	Channel shutdown due to overload																			
		0x04	Error while reading back the digital outputs																			
		0x08	Error while reading back the status of the digital outputs																			
0x10	FTT test: Temperature threshold exceeded																					
0x20	FTT test: Monitoring of auxiliary voltage is faulty																					
DOy[xx].Value [BOOL]	W	Output value for DO channels: 1 = output energized 0 = output de-energized																				

Table 19: ELOP II Factory - Digital Output System Signals

5 Operation

The remote I/O can only operated together with a controller. No specific monitoring is required for remote I/Os.

5.1 Handling

Handling of the remote I/O during operation is not required.

5.2 Diagnosis

A first diagnosis results from evaluating the LEDs, see Chapter 3.4.1.

The device diagnostic history can also be read using the programming tool.

6 Maintenance

No maintenance measures are required during normal operation.

If a failure occurs, the defective module or device must be replaced with a module or device of the same type or with a replacement model approved by HIMA.

Only the manufacturer is authorized to repair the device/module.

6.1 Faults

Refer to Chapter 3.1.1.1, for more information on the fault reaction of digital outputs.

If the test harnesses detect safety-critical faults, the module enters the STOP_INVALID state and will remain in this state. This means that the input signals are no longer processed by the device and the outputs switch to the de-energized, safe state. The evaluation of diagnostics provides information on the fault cause.

6.2 Maintenance Measures

The following measures are required for the device:

- Loading the operating system, if a new version is required
- Executing the proof test

6.2.1 Loading the Operating System

HIMA is continuously improving the operating system of the devices. HIMA recommends to use system downtimes to load a current version of the operating system into the devices.

Refer to the release list to check the consequences of the new operation system version on the system!

The operating system is loaded using the programming tool.

Prior to loading the operating system, the device must be in STOP (displayed in the programming tool). Otherwise, stop the device.

For more information, refer to the programming tool documentation.

6.2.2 Proof Test

HIMatrix devices and modules must be subjected to a proof test in intervals of 10 years. For more information, refer to the safety manual (HI 800 023 E).

7 Decommissioning

Remove the supply voltage to decommission the device. Afterwards pull out the pluggable screw terminal connector blocks for inputs and outputs and the Ethernet cables.

8 Transport

To avoid mechanical damage, HIMatrix components must be transported in packaging.

Always store HIMatrix components in their original product packaging. This packaging also provides protection against electrostatic discharge. Note that the product packaging alone is not suitable for transport.

9 Disposal

Industrial customers are responsible for correctly disposing of decommissioned HIMatrix hardware. Upon request, a disposal agreement can be arranged with HIMA.

All materials must be disposed of in an ecologically sound manner.



Appendix

Glossary

Term	Description
ARP	Address resolution protocol: Network protocol for assigning the network addresses to hardware addresses
AI	Analog input
AO	Analog output
COM	Communication module
CRC	Cyclic redundancy check
DI	Digital input
DO	Digital output
ELOP II Factory	Programming tool for HIMatrix systems
EMC	Electromagnetic compatibility
EN	European norm
ESD	Electrostatic discharge
FB	Fieldbus
FBD	Function block diagrams
FTT	Fault tolerance time
ICMP	Internet control message protocol: Network protocol for status or error messages
IEC	International electrotechnical commission
MAC address	Media access control address: Hardware address of one network connection
PADT	Programming and debugging tool (in accordance with IEC 61131-3), PC with SILworX or ELOP II Factory
PE	Protective earth
PELV	Protective extra low voltage
PES	Programmable electronic system
R	Read: The system variable or signal provides value, e.g., to the user program
Rack ID	Base plate identification (number)
Interference-free	Supposing that two input circuits are connected to the same source (e.g., a transmitter). An input circuit is termed <i>interference-free</i> if it does not distort the signals of the other input circuit.
R/W	Read/Write (column title for system variable/signal type)
SELV	Safety extra low voltage
SFF	Safe failure fraction, portion of faults that can be safely controlled
SIL	Safety integrity level (in accordance with IEC 61508)
SILworX	Programming tool for HIMatrix systems
SNTP	Simple network time protocol (RFC 1769)
SRS	System.rack.slot addressing of a module
SW	Software
TMO	Timeout
W	Write: System variable/signal is provided with value, e.g., from the user program
r_{PP}	Peak-to-peak value of a total AC component
Watchdog (WD)	Time monitoring for modules or programs. If the watchdog time is exceeded, the module or program enters the ERROR STOP state.
WDT	Watchdog time

Index of Figures

Figure 1: Connection of Actuators to Outputs	11
Figure 2: Sample Type Label	14
Figure 3: Front View	15
Figure 4: Block Diagram	15
Figure 5: Sample MAC Address Label	18
Figure 6: Label for Ex Conditions	24

Index of Tables

Table 1:	Programming Tools for HIMatrix Remote I/Os	5
Table 2:	Additional Relevant Documents	6
Table 3:	Environmental Requirements	9
Table 4:	Available Variants	13
Table 5:	Operating Voltage LED	16
Table 6:	System LEDs	16
Table 7:	Ethernet Indicators	17
Table 8:	I/O LEDs	17
Table 9:	Ethernet interfaces Properties	18
Table 10:	Network Ports in Use	18
Table 11:	Product Data	20
Table 12:	Specifications for the Digital Outputs	20
Table 13:	Certified HIMatrix F2 DO 4 01	21
Table 14:	Terminal Assignment for the Digital Outputs	22
Table 15:	Power Supply Cable Plug Properties	23
Table 16:	Input and Output Cable Plug Properties	23
Table 17:	SILworX - System Parameters for Digital Outputs, Module Tab	26
Table 18:	SILworX - System Parameters for Digital Outputs, DO 4: Channels Tab	27
Table 19:	ELOP II Factory - Digital Output System Signals	28

Index

block diagram.....	15	safeethernet	18
diagnosis.....	29	safety function	11
fault reaction		specifications.....	20
digital outputs	12	SRS	13
front view.....	15		



SAFETY
NONSTOP

HIMA Paul Hildebrandt GmbH + Co KG

P.O. Box 1261

68777 Brühl, Germany

Phone: +49 6202 709-0

Fax: +49 6202 709-107

E-mail: info@hima.com Internet: www.hima.com

(1334)